

HFE7

SUBMINIATURE INTERMEDIATE POWER RELAY



File No.:E134517



File No.:40027342

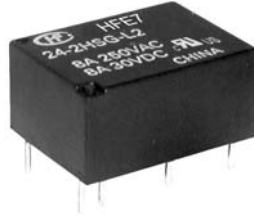

Features

- High switching capacity
1A, 1B: 10A 250VAC/8A 30VDC;
2A, 2B, 1A + 1B: 8A 250VAC/30VDC
- High sensitive
- 4kV dielectric strength (between coil & contacts)
- Single side stable and latching types available
- 1 Form A, 1 Form B, 2 Form A and 1A + 1B contact arrangement
- Environmental friendly product (RoHS compliant)
- Outline Dimensions: (20.0 x 15.0 x 10.2) mm

CONTACT DATA

Contact arrangement	1A, 1B	2A, 2B, 1A + 1B
Contact resistance	Gold AgNi plated: 30mΩ (at 1A 6VDC) No gold AgNi plated: 50mΩ (at 1A 6VDC) Gold AgSnO ₂ plated: 60mΩ (at 1A 6VDC) No gold AgSnO ₂ plated: 80mΩ (at 1A 6VDC)	
Contact material	AgSnO ₂ , AgNi	
Contact rating (Res. load)	10A 250VAC/30VDC	8A 250VAC/30VDC
Max. switching Voltage	277VAC	277VAC
Max. switching current	10A	8A
Max. switching power	2500VA	2000VA
Mechanical endurance	1 x 10 ⁷ OPS	
Electrical endurance	1 x 10 ⁵ OPS (2 Form A: 3 x 10 ⁴ OPS)	

CHARACTERISTICS

Insulation resistance	1000MΩ (at 500VDC)	
Dielectric Strength	Between coil & contacts	4000VAC 1min
	Between open contacts	1000VAC 1min
Pulse width of coil	50ms min. (Recommend: 100ms to 200ms)	
Operate time (at nomi. volt.)	10ms max.	
Release (Reset) time (at nomi. volt.)	10ms max.	
Max. operate frequency (under rated load)	20cycles /min	
Temperature rise (at nomi. volt.)	50K max.	
Vibration resistance	10Hz to 55Hz 1.5mm DA	
Shock resistance	98m/s ²	
Humidity	5% to 85% RH	
Ambient temperature	-40 °C to 70 °C	
Termination	PCB	
Unit weight	Approx. 6g	
Construction	Plastic sealed, Flux proofed	

Notes: The data shown above are initial values.

COIL

Coil power	1 Form A, 1A+1B single side stable	200mW
	1 coil latching	200mW
	2 Form A single side stable	280mW
	2 coils latching	280mW

COIL DATA

at 23°C

1 Form A, 1A+1B Single side stable (200mW)

Nominal Voltage VDC	Pick-up Voltage VDC	Drop-out Voltage VDC	Coil Resistance x (1±10%)Ω
3	2.1	0.3	45
5	3.5	0.5	125
6	4.2	0.6	180
9	6.3	0.9	405
12	8.4	1.2	720
24	16.8	2.4	2880

2 Form A Single side stable (280mW)

Nominal Voltage VDC	Pick-up Voltage VDC	Drop-out Voltage VDC	Coil Resistance x (1±10%)Ω
3	2.1	0.3	32.1
5	3.5	0.5	89.3
6	4.2	0.6	129
9	6.3	0.9	289
12	8.4	1.2	514
24	16.8	2.4	2056

1 coil latching (200mW)

Nominal Voltage VDC	Set / Reset Voltage VDC	Coil Resistance x (1±10%)Ω
3	2.1	45
5	3.5	125
6	4.2	180
9	6.3	405
12	8.4	720
24	16.8	2880



HONGFA RELAY

ISO9001, ISO/TS16949, ISO14001, OHSAS18001, IECQ QC 080000 CERTIFIED

2010 Rev. 1.00

COIL DATA

at 23°C

2 coils latching (280mW)

Nominal Voltage VDC	Set / Reset Voltage VDC	Coil Resistance x (1±10%)Ω
3	2.1	32.1+32.1
5	3.5	89.3+89.3
6	4.2	129+129
9	6.3	289+289
12	8.4	514+514
24	16.8	2056+2056

SAFETY APPROVAL RATINGS

UL/CUL (AgNi)	1 Form A	10A 250VAC 8A 30VDC 1/4HP 125VAC 1/3HP 250VAC
	2 Form A	8A 250VAC/30VDC 1/4HP 125VAC 1/3HP 250VAC
	1 A +1 B	8A 250VAC/30VDC 1/4HP 125VAC 1/3HP 250VAC

Notes: Only some typical ratings are listed above. If more details are required, please contact us.

ORDERING INFORMATION

Type	HFE7 / 12 -1H S T G -L2 -R (XXX)						
Coil voltage	3, 5, 6, 9, 12, 24VDC						
Contact form	1) 1H: 1 Form A 1D: 1 Form B 2H: 2 Form A 2D: 2 Form B 1HD: 1A+1B						
Construction ²⁾	S: Plastic sealed Nil: Flux proofed						
Contact material	T: AgSnO ₂ Nil: AgNi						
Contact plating	G: Gold plated Nil: No gold plated						
Sort	L1: 1 coil latching L2: 2 coils latching Nil: Single side stable						
Polarity	R: Reverse polarity Nil: Positive polarity						
Customer special code							

Notes: 1) 1H, 2H means that relay is on the "reset" status when delivery; 1D, 2D means that relay is on the "set" status when delivery.

2) Under the ambience with dangerous gas like H₂S, SO₂ or NO₂, plastic sealed type is recommended; Please test the relay in real applications.

OUTLINE DIMENSIONS, WIRING DIAGRAM AND PC BOARD LAYOUT

Unit: mm

Outline Dimensions

Single side stable & 1 coil latching

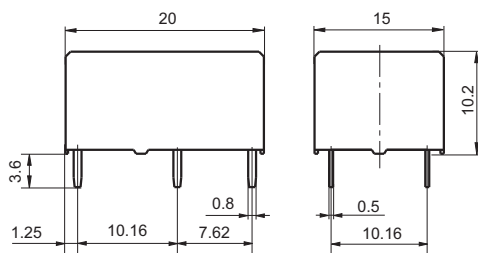

2 coils latching

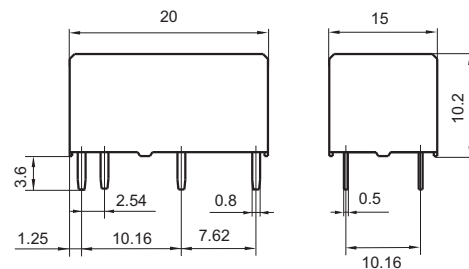

PCB Layout (Bottom view)

Single side stable & 1 coil latching

2 coils latching

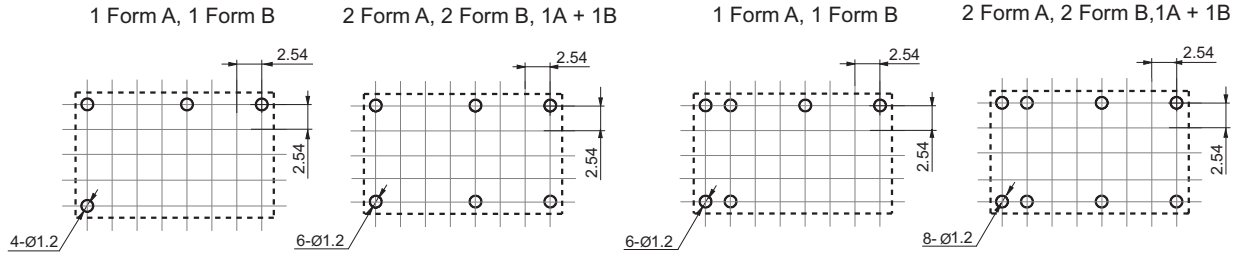

- Remark: 1) In case of no tolerance shown in outline dimension: outline dimension $\leq 1\text{mm}$, tolerance should be $\pm 0.2\text{mm}$; outline dimension $> 1\text{mm}$ and $\leq 5\text{mm}$, tolerance should be $\pm 0.3\text{mm}$; outline dimension $> 5\text{mm}$, tolerance should be $\pm 0.4\text{mm}$.
 2) The tolerance without indicating for PCB layout is always $\pm 0.1\text{mm}$.
 3) The width of the gridding is 2.54mm.

Wiring Diagram (Bottom view)

Single side stable (Positive polarity)

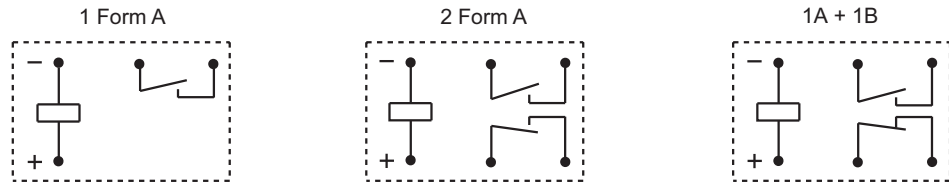

1 coil latching (Positive polarity)

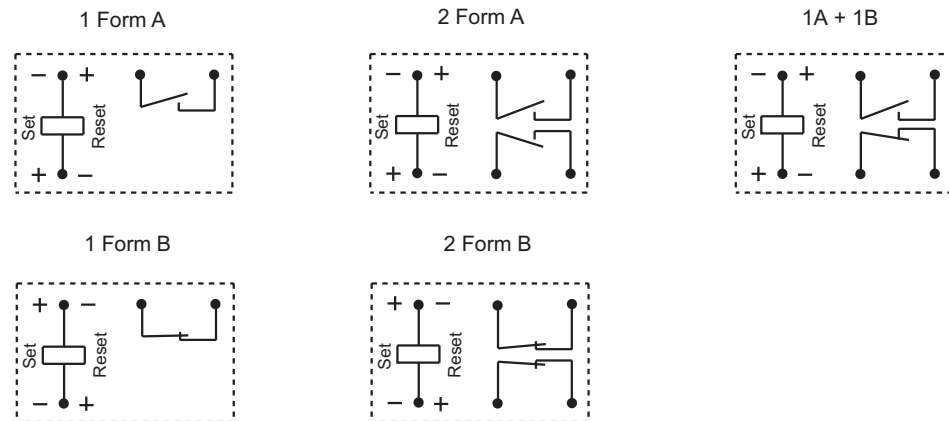

Wiring Diagram (Bottom view)

2 coils latching (Positive polarity)

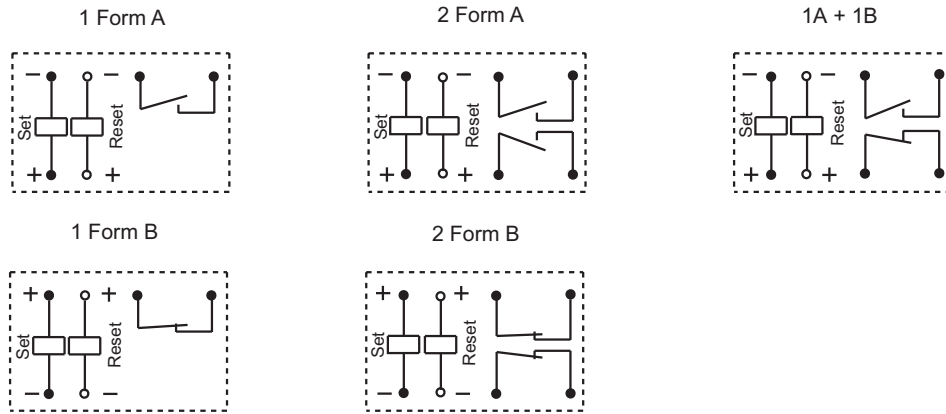

Remark: The coil polarity of Reverse polarity and Standard polarity is opposite.

Notice

1. Relay is on the "reset" or "set" status when being released from stock, with the consideration of shock risen from transit and relay mounting, relay would be changed to "set" or "reset" status, therefore, when application (connecting the power supply), please reset the relay to "set" or "reset" status on request.
2. In order to maintain "set" or "reset" status, energized voltage to coil should reach the rated voltage, impulse width should be 5 times more than "set" or "reset" time. Do not energize voltage to "set" coil and "reset" coil simultaneously. And also long energized time (more than 1 min) should be avoided.
3. In order to avoid changing operate voltage, products should not be kept in strong magnetic field during transportation, storage and application.

Disclaimer

This datasheet is for the customers' reference. All the specifications are subject to change without notice. We could not evaluate all the performance and all the parameters for every possible application. Thus the user should be in a right position to choose the suitable product for their own application. If there is any query, please contact Hongfa for the technical service. However, it is the user's responsibility to determine which product should be used only.