

HF8

SUBMINIATURE INTERMEDIATE POWER RELAY



File No.:E134517



File No.:40025189



Features

- 10A switching capability
- 4kV impulse withstand voltage (between coil and contacts)
- 1 Form A and 1 Form C configurations
- Subminiature, high sensitive, PCB layout
- Plastic sealed type for automatic wave soldering
- Environmental friendly product (RoHS compliant)
- Outline Dimensions: (21.3 x 16.2 x 14.4) mm

CONTACT DATA

Contact arrangement	1A, 1C
Contact resistance	100mΩ (at 1A 24VDC)
Contact material	AgNi, AgCdO
Contact rating (Res. load)	10A 125VAC (Only for HF8-1AT/1CT) HF8: 6A 300VAC/28VDC HF8A: 6A 277VAC/30VDC
Max. switching voltage	300VAC / 30VDC
Max. switching current	10A
Max. switching power	1800VA / 300W
Mechanical endurance	1 x 10 ⁷ OPS
Electrical endurance	1 x 10 ⁵ OPS

CHARACTERISTICS

Insulation resistance	100MΩ (at 500VDC)	
Dielectric strength	Between coil & contacts	2000VAC 1min
	Between open contacts	750VAC 1min
Operate time (at nomi. volt.)	6ms max.	
Release time (at nomi. volt.)	3ms max.	
Humidity	5% to 98% RH	
Ambient temperature	-55°C to 90°C	
Shock resistance	Functional	98m/s ²
	Destructive	980m/s ²
Vibration resistance	10Hz to 55Hz 1.5mm DA	
Termination	PCB	
Unit weight	Approx. 11g	
Construction	Plastic sealed, Flux proofed	

Notes: 1) The data shown above are initial values.
2) Please find coil temperature curve in the characteristic curves below.

COIL

Coil power	Standard: 450mW (48VDC: 600mW) Sensitive: 330mW
------------	--

COIL DATA

at 23°C

Standard type

Nominal Voltage VDC	Pick-up Voltage VDC	Drop-out Voltage VDC	Max. Allowable Voltage VDC	Coil Resistance Ω
3	2.25	0.15	3.90	20 x (1±10%)
5	3.75	0.25	6.50	56 x (1±10%)
6	4.50	0.30	7.80	80 x (1±10%)
9	6.75	0.45	11.7	180 x (1±10%)
12	9.00	0.60	15.6	320 x (1±10%)
18	13.5	0.90	23.4	720 x (1±10%)
24	18.0	1.20	31.2	1280 x (1±10%)
48	36.0	2.40	62.4	3800 x (1±10%)

Sensitive type

Nominal Voltage VDC	Pick-up Voltage VDC	Drop-out Voltage VDC	Max. Allowable Voltage VDC	Coil Resistance Ω
3	2.25	0.15	3.90	28 x (1±10%)
5	3.75	0.25	6.50	80 x (1±10%)
6	4.50	0.30	7.80	110 x (1±10%)
9	6.75	0.45	11.7	250 x (1±10%)
12	9.00	0.60	15.6	440 x (1±10%)
18	13.5	0.90	23.4	1000 x (1±10%)
24	18.0	1.20	31.2	1780 x (1±10%)
48	36.0	2.40	62.4	7120 x (1±10%)

Notes: When requiring pick-up voltage < 75% of nominal voltage, special order allowed.



HONGFA RELAY

ISO9001, ISO/TS16949, ISO14001, OHSAS18001, IECQ QC 080000 CERTIFIED

2010 Rev. 1.00

SAFETY APPROVAL RATINGS

UL/CUL	Medium Duty HF8-1CH/1AH	6A 28VAC 6A 300VAC
	Heavy Duty HF8-1AH	10A 24VDC 10A 125/120VAC
	Heavy Duty HF8-1CT	7A 277VAC 10A 125VDC
	General Duty HF8-1C/1A	2A 28VDC 2A 300VAC 3A 120VDC
	HF8A	6A 30VDC(NO/NC) 6A 277VAC(NO/NC)
VDE	HF8....A	2.5A 250VAC COSØ=0.4 2.5A 250VAC COSØ=0.5 5A 250VAC COSØ=1 6A 250VAC COSØ=1

Notes: Only some typical ratings are listed above. If more details are required, please contact us.

ORDERING INFORMATION

	HF8 HF8A	-1C	H	12	-D	S	E	F	(XXX)
Type	HF8: Standard type HF8A: Low cost type								
Contact arrangement:	1A: 1 Form A 1C: 1 Form C								
Contact capacity	H: Medium Duty (6A) T: Heavy Duty (10A, Only for HF8) Nil: General Duty (3A/2A)								
Coil voltage	3, 5, 6, 9, 12, 18, 24, 48VDC								
Coil voltage form	D: DC								
Coil power	S: Sensitive Nil: Standard								
Construction ¹⁾	E: Plastic sealed Nil: Flux proofed								
Insulation standard	F: Class F A: Class A (VDE version, Only for HF8-1AH/1CH) Nil: Class B								
Customer special code									

Notes: 1) Under the ambience with dangerous gas like H₂S, SO₂ or NO₂, plastic sealed type is recommended; Please test the relay in real applications.
If the ambience allows, flux proofed type is preferentially recommended.
If water cleaning is required after the relay is assembled on PCB, please contact us for suggestion about suitable parts.

OUTLINE DIMENSIONS, WIRING DIAGRAM AND PC BOARD LAYOUT

Unit: mm

Outline Dimensions

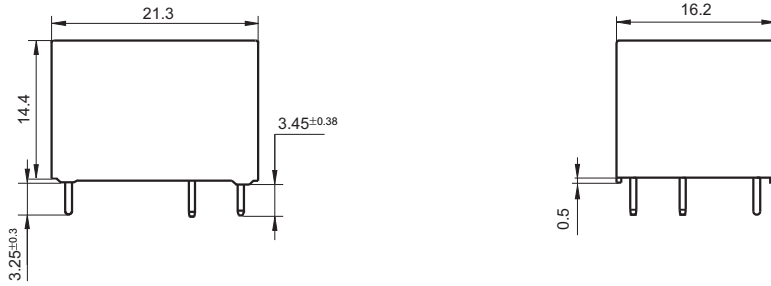

PCB Layout (Bottom view)

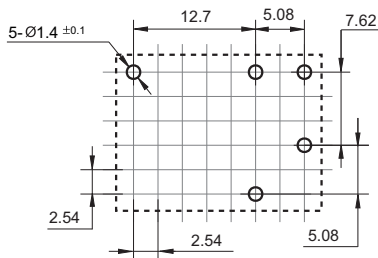

Wiring Diagram (Bottom view)

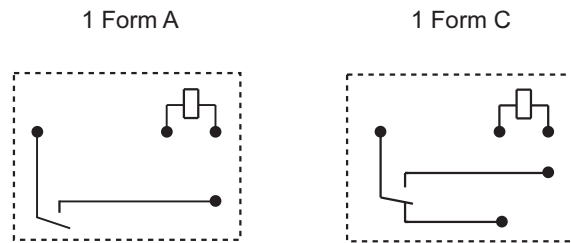

- Remark: 1) In case of no tolerance shown in outline dimension: outline dimension $\leq 1\text{mm}$, tolerance should be $\pm 0.2\text{mm}$; outline dimension $> 1\text{mm}$ and $\leq 5\text{mm}$, tolerance should be $\pm 0.3\text{mm}$; outline dimension $> 5\text{mm}$, tolerance should be $\pm 0.4\text{mm}$.
 2) The tolerance without indicating for PCB layout is always $\pm 0.1\text{mm}$.
 3) The width of the gridding is 2.54mm.

CHARACTERISTIC CURVES

MAXIMUM SWITCHING POWER

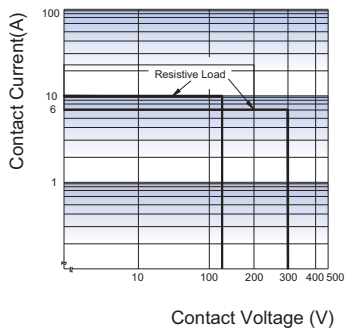

ENDURANCE CURVE

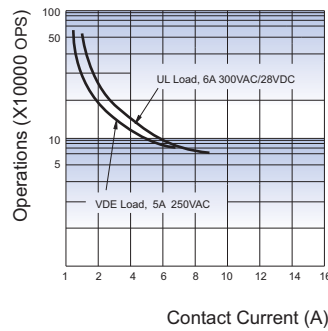

COIL TEMPERATURE RISE

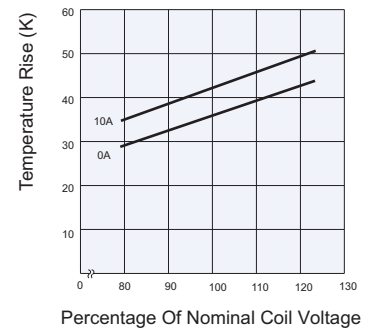

Disclaimer

This datasheet is for the customers' reference. All the specifications are subject to change without notice. We could not evaluate all the performance and all the parameters for every possible application. Thus the user should be in a right position to choose the suitable product for their own application. If there is any query, please contact Hongfa for the technical service. However, it is the user's responsibility to determine which product should be used only.

© Xiamen Hongfa Electroacoustic Co., Ltd. All rights of Hongfa are reserved.